



TOWARDS A UNIFIED REGISTRATION SYSTEM

A Unified Registration System for the Engineering and Cognate Professions

(a revised discussion paper)

1 INTRODUCTION

- 1.1 The fourth draft of this discussion paper was discussed by College Boards, early in 2002, supported by the Board of Engineering Practice and given in-principle support by National Congress in March 2002. In May 2002, Council ratified the National Engineering Registration Board's proposal and recommendation for a unified registration system to include engineering professionals and related professionals.
- 1.2 The discussion paper has been revised to accommodate the Stage 1 competency standards, ratified in July 2005, revised Stage 2 competency standards, reissued in November 2003 and a policy on approval of new areas of practice, adopted by the National Engineering Registration Board in November 2004.
- 1.3 The National Engineering Registration Board is to carry forward the proposal for the unified registration system as described in this paper. The Board will also develop or adopt rules for recognising certification bodies that have acceptable processes for determining and applying competencies to the certification of competent persons for the purposes of registration.

2 EXECUTIVE SUMMARY

- 2.1 The discussion paper reviews the background to registration and the evolution of the two registers Engineers Australia administers on behalf of the profession. Incongruities between the registers are expanded into an argument that registration should be more about what a person is competent to do than about academic qualifications alone. This argument is developed with reference to both academic and professional competencies towards a proposal that a unified register could incorporate various occupational groups.
- 2.2 The unified registration system, being focussed on what registered persons are competent to do in the workplace, seeks the contribution of competency authorities to define new areas and certification authorities to ensure that only competent people are registered. The discussion paper proposes how a unified register could both designate persons competent in areas of practice and distinguish between their occupational groups.
- 2.3 Finally the discussion paper reviews the benefits and pitfalls of progressing the proposal to move towards a unified register and recommends that the National Engineering Registration Board should refer the discussion paper to its Future Directions Working Party for further refinement before wider distribution for comment.
- 2.4 The Board approved the discussion paper on 2 March 2007.

3 BACKGROUND

- 3.1 Since 1990, three occupational groups have emerged within the engineering profession in Australia, professional engineers, engineering technologists and engineering associates (officers). A person's occupational group corresponds with his or her original qualification, normally a BEng (4 years), a BTech (3 years) or a TAFE Diploma (2 years), respectively.

- 3.2 However, it could be argued that a person should be registered on the basis that he or she could satisfy a set of carefully defined competencies, no matter what the original qualification. Indeed, original qualifications do not seem to be nearly so important to registration as the observable functions that are carried out competently in the workplace. Indeed, the integrity of the registration system demands that applicants should be assessed against objective competency standards in a way that is both visible and defensible.
- 3.3 Engineers Australia administers two national registers, one for professional engineers and one for technologists. The registers are administered to safeguard the community, at no cost to government, with a particular emphasis on public safety and the risks associated with information imbalance in an engineer-client relationship.
- 3.3.1 Public safety is protected when only competent practitioners are registered and provide engineering services in critical areas. Registered practitioners will be engaged to provide services in such areas only if stipulated by regulation or demanded by the market for engineering services.
- 3.3.2 Information imbalance is alleviated when registration standards are made available. Published information must express the observable functions and responsibilities that are necessary to practise competently in each area of the register in terms of competency-based eligibility criteria.
- 3.4 Currently far more professional engineers are registered than engineering technologists. This is most likely because engineering technologists and engineering associates, almost by virtue of their training and the nature of their specialities, work within quite specific technologies or fields of activity, and registration in this form has not been widely available to them. However, in times when greater responsibility is being assumed by the individuals that undertake work, registration may soon become more important to them than it was.
- 3.5 Competency standards at Stage 1, ratified in July 2005, provide a statement of competency that is equivalent to the required qualification for each of the occupational groups. This opens a pathway to registration that was not previously available, as these competencies can be addressed in the absence of an accepted qualification.
- 3.6 This paper explores the arguments for a new approach to registration for the engineering profession that accommodates competent persons from all occupational groups in a unified registration system that takes account of an individual's capacity and need to accept responsibility for work.

4 A UNIFIED REGISTRATION SYSTEM

- 4.1 The National Professional Engineers Register (NPER) has gained wide recognition since 1994. Local authorities, engineering employers and government agencies frequently refer to NPER when specifying a competent professional engineer to provide engineering services. NPER is the basis of the Institution's Scheme for the Accreditation of Certifiers under the NSW Environmental Planning and Assessment Act.
- 4.2 NPER is well known and respected. However, its success appears to make it all the more difficult to launch a second register. So, is there some way in which NPER can be broadened and adapted to embrace a wider constituency? Is it possible to structure a unified registration system to provide a place for all members of the engineering profession, but which also preserves the identity of each occupational group? Can engineering technologists and engineering associates be registered in areas of practice that recognise their capacity to accept responsibility for their work, without jeopardising the integrity or reputation of the register?

5 BUILDING A UNIFIED REGISTRATION SYSTEM FOR THE ENGINEERING PROFESSION

5.1 The National Engineering Registration Board established a principle in 1998 that a single competency panel should “manage” an area of practice that is to be available in both NPER and NETR. It was also the express wish of the Board that standards of competence exercised by persons registered on NETR should be no less than those exercised by persons registered on NPER in a corresponding registration area. Accordingly the idea has developed that areas of practice in NETR should be closely aligned with suitable specific areas of practice in NPER. The Board, or a committee that it appoints for the purpose, would need to endorse the description of the engineering responsibilities involved in specific areas.

5.2 The proposal for a unified registration system requires the abolition of an accepted policy that a person must register on NPER in a general area of practice before registering in a specific area. To register a person in a specific area of practice who would not qualify for registration on NPER in a general area of practice, the eligibility criteria for the specific area must define essential underpinning knowledge criteria as well as workplace competencies. This would be achieved by expanding the eligibility criteria for a specific area of practice to specify:

1. the relevant area of practice in sufficient detail to inform a client what services to expect from a person who is duly registered on it;
2. the qualification or generic engineering competency at Stage 1 required for registration;
3. the generic engineering competency at Stage 2 required for registration;
4. key occupational competencies to be demonstrated by the applicant’s evidence of competent practice in the area;
5. assessment procedures to be followed in coming to a decision to register the applicant;
6. the relevant external competency authority or certification authority;
7. non engineering backgrounds that are acceptable in the science and technology sectors.

5.3 These above criteria warrant expansion as they embody a significant shift in the approach to specifying areas of practice.

1. Guidelines for specific areas of practice offer, in terms that a non-engineer can understand, a description of the engineering services and capacity of the registered practitioner to accept responsibility for work that are involved in competent practice in the field of engineering. Criteria should include sufficient information to provide the basis for establishing and agreeing a scope of work to be done, for allocating responsibilities or forming a contract for engineering services.
2. By providing for a statement of the minimum requirements for registration in terms of qualifications or generic engineering competency at Stage 1, it becomes possible to broaden the basis of the qualification necessary for a specific area of practice, where that reflects what is acceptable in the workplace. Specific areas of practice already exist where a TAFE Diploma supplemented by workplace training can provide an adequate knowledge for registration, for example, as a design verifier of gas bottles and simple air receivers. As a principle, it could be argued that a TAFE Diploma topped up by a relevant university based “Masters” qualification could provide sufficient competency at Stage 1 for most existing specific areas of practice. However, the acquisition of competency should not be limited by the perceived pathway possibilities, but may be tested by examination.

3. Significant changes to the generic competency standards at Stage 2 have made possible clearer identification of the distinctions between professional engineers and engineering technologists where they are expressed in terms of their knowledge and understanding, expertise, responsibilities for outcomes and management roles. Each of these aspects affects the definition of competency required for each area of practice in a different way.
4. It is recognised that within a field it is possible for practitioners to major in certain definable specialisms. It is therefore incumbent on the Competency Panel to decide the range of engineering involvement needed for competent practice in the field (see Addendum A). In the past, some areas of involvement have been seen as mandatory and others as optional. Guidelines for Fire Safety Engineering and Pressure Equipment Design Verification both have examples of these. In the latter, some of the optional areas become mandatory for certain specialisms, for example the design verification of pressure piping requires competency in threaded and flanged joints. Occupational competencies add value to the generic competencies specified in the national standards at Stage 1 and Stage 2. Competency criteria may pre-exist the establishment of the specific area of practice, for example where Standards Australia has established competency standards through its committee system, such as in AS/NZS 4761 Part 1 – *competencies for working with electrical equipment in hazardous areas*. In whatever way they are established, occupational competencies must be expressed in terms that are recognisable by practitioners, employers and clients familiar with the industry in which registered persons work.
5. The competency-based assessment system underpins registration on the national registers. It has proved to be robust and provides defensible outcomes of appraisals against objective criteria. In each specific area of practice, the Competency Panel must determine the nature of evidence that an applicant must present (for example, should it include examples of work done in the area?). The Competency Panel must also determine how that evidence is to be evaluated against the eligibility criteria (Will there be an interview? Is a desk assessment sufficient? Is an examination to test underpinning knowledge needed?).
6. Reference to external competency authorities has been made in the context of *competencies for working with electrical equipment in hazardous areas*, where the competency authority is a Standards Australia committee producing AS/NZS 4761. An external competency authority is a body that is independent of the registration system that determines competencies that are necessary to practise in the field of engineering defined by the area of practice in the register. It is also necessary to accept that certification of the achievement of competencies may also be made by an external certification authority. An external certification authority is a body that provides a certificate of competency in the field of engineering defined by the area of practice in the register. The Board would need mechanisms to check an external certification authority's capacity to provide defensible certification of competency, possibly through an accreditation process that has yet to be determined.
7. It is to be noted at this point that the next logical step could be to extend registration into a broader Science, Engineering and Technology environment where Engineers Australia would be working alongside non-engineer bodies. An example of the first step in this direction might be the registration of engineering geologists, whose competence in landslide risk management had been certified by the Australian Geomechanics Society.

Key Bodies	Competency Authority	Certification Authority
Constituency	Represents all Stakeholders <ul style="list-style-type: none"> • Engineers Australia Colleges • Technical Societies • Cognate Associations • Client groups • Industry Regulators (Gov't) • Standards writers 	Mainly Practitioners <ul style="list-style-type: none"> • Government Agencies • Recognised industry leaders • Engineers Australia Assessors • RTO's (per ANTA) • Professional associations • Technology Institutes
Functions	Sets criteria <ul style="list-style-type: none"> • Defines area of practice • Underpinning knowledge • Writes competencies • Responsibility for outcomes • Specifies required evidence • Defines assessment process 	Assesses Competency <ul style="list-style-type: none"> • Evaluates evidence • Reasons for decision • Records outcome • Issues certificate

5.4 The shift in approach is a natural development of a registration system that has evolved under the guidance of the National Engineering Registration Board over the period since 1994. The change is more evolutionary than revolutionary. However it will challenge Engineers Australia's Competency Panels to think more carefully about who is currently practising competently in the fields of engineering they speak for.

6 APPEARANCE OF THE UNIFIED REGISTRATION SYSTEM

- 6.1 The concept of a unified registration system for the engineering profession and cognate professions presents exciting opportunities for developing a single web-based site where all three occupational groups can be accessed through areas of practice that are tailored to their needs. The chartered status of members of Engineers Australia, CPEng, CEngT and CEngO would clearly distinguish the occupational categories of their registration. PEng, EngT and EngA could similarly distinguish the occupational categories of non-members. In the future this concept could be extended to register practitioners from the science and technology sectors.
- 6.2 What would the unified registration system look like to the enquirer? It is actually quite helpful to think about the registration system in terms of its appearance to an enquirer. What kind of information will be presented? What guidance will be provided in selecting a competent practitioner? What constraints will be placed on searching for a person to provide a particular engineering or related service? How would criteria used in the assessment for the certification of competence be presented to the enquirer?
- 6.3 The National Engineering Registration Board offers a search facility known as Registered Professional Search (RPSearch). RPSearch helps potential clients and the end users of engineering and engineering related services to locate a registered professional in the, engineering, technology and science sectors in Australia.
- 6.4 RPSearch currently lists Registered Professional Engineers and Registered Engineering Technologists. With the support of interested professional associations, government agencies and independent training organisations, the Board will continue to develop the unified registration system ultimately to include engineering associates and cognate professionals with science and technology backgrounds in engineering related fields.

Categories & subcategories	Personal Information	Professional Designation	More information notes
Individual	Family Name Given Names		Search for an individual against all criteria lists all areas of registration and gives details of occupational groups through postnominals and related notes.
Occupational Group	Professional Engineer	CPEng or PEng	Professional Engineers apply their structured learning, critical perception and engineering judgment to challenge current thinking, often engaging in research and development in new and existing fields. They reframe situations by applying their powers of analysis, synthesis and well developed grasp of engineering theory to plan and design original and novel solutions to problems. Their understanding of fundamental principles in science and technology fits them to create and apply new engineering practices on a regular basis. Registered Professional Engineers comprehend complexity and function independently, or display leadership within multi-disciplinary and cross-cultural teams, to optimise costs and benefits to clients and community while achieving desired outcomes within the context of a safe and sustainable environment. They accept responsibility for the selection and application of design tools, implementation strategies and overall functionality of engineering solutions.
	Engineering Technologist	(CEngT) or EngT	Engineering Technologists apply scientific and technological principles to deliver in depth knowledge of devices, equipment, components and processes in their particular technical fields. Their education and experience fits them to modify established engineering technology and apply newly developed engineering technologies on a regular basis and to provide leadership in design, design review, operational and supervisory activities within their field. Registered Engineering Technologists provide leadership and management qualities that enable the deployment of human, technological and financial resources to meet enterprise needs within the context of safe and sustainable environment. They accept responsibility for ensuring that engineering solutions meet accepted minimum standards for the safety and welfare for the community by identifying non-compliance and contributing to corrective actions in order to achieve the specified objectives.
	Engineering Associate	(CEngO) or EngO	Engineering Associates apply practical techniques of analysis, technical principles, standards and practices to achieve given engineering objectives within the scope of prescriptive codes of practice and recognised standards, relying on precedent and established procedures for guidance. Their detailed knowledge of specific practices enables them to have regard to financial, environmental and risk factors in managing and supervising such activities. Registered Engineering Officers (Associates) are accountable for the design details and accurate installation of devices, equipment, components and processes within their field of activity. They accept responsibility for the internal consistency and integrity of the things they deal with.
	Related Professional	As available	The integration of Science and Technology into the registration system has been accepted where there is a demonstrated safety issue. An example of this discussed in the paper is the registration of engineering geologists engaged in landslide risk management. A certification authority (such as Australian Geomechanics Society) would provide information on competency-based eligibility criteria for the register.
General Area of Practice (professional engineers only)	Civil Electrical Structural Etc.	Normally CPEng or PEng	Eg. Civil Engineers are concerned with materials such as steel, concrete, timber, earth and rock, and with their application in the research, design, development, manufacture, construction, operation, maintenance and management of hydraulic, structural, environmental and systems aspects of infrastructure works and services such as water, sewerage, transport, urban development and municipal services, and with building and construction for other infrastructure industries. Some general areas of practice rely on much more detailed information.
Specific Area of Practice	Subdivisional Geotechnics Etc.	Could be CPEng (PEng) or CEngT (EngT)	"More Information" will direct the enquirer to the Guidelines for Applicants using a web based hyper-link. The guidelines will be written with non-engineer readers in mind and will also explain the minimum knowledge criteria, for example "an Associate Diploma and verifiable knowledge of certain Australian Standards.
Accreditation Schemes	Principal Certifier Building	PC-B or PC-B(1&10)	"More Information" will direct the enquirer to the Guidelines for Applicants normally through the Internet. Cross-links to government web sites could be used where the area of practice is part of an authorised scheme.
Where do they practise?	Business Address Business Phone, Fax and e-mail		Possible to search for registered persons by suburb, state, country etc. [Searching for persons in metropolitan centres (Sydney etc) could use an algorithm that includes adjacent suburbs.]

Categories & subcategories	Personal Information	Professional Designation	More information notes
Who certified competency?	Engineers Australia Related Professional	Engineering professionals Cognate professionals will be distinguished by their academic qualifications and professional affiliations	Engineers Australia will normally be the certification authority for professional engineers and engineering technologists. Engineers Australia may participate in certification of competency for Associates, but so may TAFE institutes, RTOs under the Australian qualifications framework and major engineering employers. The register will make it clear who is the certification authority in each case. Engineers Australia will establish validation processes to satisfy itself of the capacity of certification authorities it accepts. For external certifying authorities there would be a link to their Internet site for competency eligibility criteria and certification procedures.
Other matters	Insurance Etc.		The register provides information on PI insurance where insurance is mandated by an authorised scheme.

6.5 How would this work?

6.6 The involvement of the engineering profession in the building industry provides some pertinent examples of areas of practice that could be tailored to the needs of competent professional engineers, engineering technologists and engineering associates, for example:

- A Professional Engineer leads the fire safety engineering design, carrying responsibility for design parameters, hazard identification, analysis methodology and conceptual designs. They would be registered as **Fire Safety Engineers**.
- An Engineering Technologist participates in or leads fire safety engineering design work and may carry responsibility for checking and certifying compliance of alternative solutions before, during and after system installation. They could be registered **Fire Safety Certifiers** or **Fire Safety Designers**.
- An Engineering Associate (officer) participates in design, installation or certification of work using specialist knowledge of building regulations and the standards for certain components of the system, such as the plumbing and heads of a sprinkler system. They would be registered as a **Fire Safety Specialists** or a **Fire Safety Regulatory Authorities**.

6.7 A unified registration system could include all these areas of practice. For each area, there would be a comprehensive description of the work covered by it and the competencies that would be necessary to practice competently in it. Responsibility for competency based eligibility criteria would be allocated to a Competency Panel as described in Addendum A. Competencies would include any necessary qualification or combination of qualifications considered essential or a comprehensive statement of required underpinning knowledge, such as is contained in AS/NZS 4761 Part 1. With such an arrangement only the minimum necessary qualifications or Stage 1 competencies would be included. It would be possible to move away from the rather superfluous requirement for a bachelor of engineering to register as a plumbing plan certifier (as provided for by the ACT Construction Occupations Licensing Regulations 2004) or to register as a fire sprinkler designer (which could be useful under the Victorian Building Act).

6.8 General areas of practice would continue to be for professional engineers only. To qualify, a person would hold a degree from a four-year accredited engineering education program or would have satisfied the Stage 1 competencies for a professional engineer. The benchmark for general areas of practice in NPER would remain the Stage 2 competencies for professional engineers. The title, Chartered Professional Engineer – CPEng (current year), is the designation of professional engineers, registered on NPER, who are also members of Engineers Australia.

- 6.9 On the other hand, specific areas of practice, where appropriate, would no longer be kept exclusively for professional engineers. This is consistent with the thought that original qualifications do not seem nearly so relevant to registration as the observable functions in the workplace. The definition of competencies will need to include underpinning competencies at Stage 1 as well as the necessary Stage 2 competencies. Definition of those competencies may be undertaken by competency authorities and their assessment and certification by certification authorities that are independent from but acceptable to the registration system.

7 BENEFITS AND PITFALLS OF A UNIFIED REGISTRATION SYSTEM

- 7.1 Before integrating the proposed changes into an existing registration system that is working well in many ways, it is essential to weigh up the benefits they could deliver and consider carefully any risks that might emerge. The greatest attraction of the unified registration system is its inherent simplicity, particularly from the public perspective. The greatest pitfall may be the potential for misunderstanding by the engineering profession itself.
- 7.2 The benefits of the unified registration system can be summarised along the following lines:
- It builds on a well-accepted register for professional engineers.
 - It develops the existing philosophy of matching registration with regulatory needs in a way that is not exclusive to professional engineers.
 - It is consistent with the trends towards competency-based assessment being adopted by most professions, especially our own.
 - It recognises that regulations tend to prescribe compliance in terms of the application of proven technologies that have normally been captured by codes of practice and Australian Standards.
 - It invites external competency authorities to propose areas of practice for registration and broadens the spectrum of professional involvement that might be captured by the registration system.
 - It accepts the role of external certification authorities in engineering and engineering related sectors, subject only to a reasonable accreditation system.
 - It recognises the reality of the marketplace where there is often no clear distinction between engineers, technologists, associates and related professionals.
 - It aims to provide employers or potential clients with more comprehensive information on what a person registered in a particular area of practice might be expected to deliver.
 - On the face of it, the proposition is more equitable than using cascading registers based only on original qualifications.
 - It avoids the complication of explaining to a potential client why a person on one register should be preferred to a person on another, even though their area of practice and relevant competency within it might be substantially equivalent.
 - It broadens the influence of the National Engineering Registration Board through the continuum of science, engineering and technology.
- 7.3 The risks to the success of a unified registration system for the engineering and cognate professions can be summarised along the following lines:
- Some professional engineers might feel that the standard of registration would be compromised in the process of implementing this proposal and would require reassurance that sufficient checks are in place to avoid compromising regulation.

- Some engineers could feel their status or dignity is infringed by the inclusion of engineering technologists or engineering associates on the same register as they.
- Inadequately resourcing the upgrade of the current competency statements for existing areas of practice and failing clearly to express the minimum required qualifications or underpinning knowledge based on Stage 1 competency standards might result in unqualified and inexperienced practitioners applying for registration.
- The more comprehensive capability statements on which the unified registration system is based would require more detailed research and more careful expression than current guidelines on eligibility. There is the risk of an associated increase in administration costs.
- The proposal also requires the development of an accreditation system for external certification authorities such as TAFE Institutes, Registered Training Organisations or independent bodies like the Australian Institute for the Certification of Inspection Personnel (AICIP), if registration is to be offered to personnel they certificate.

7.4 Further benefits and risks associated with the proposal will inevitably emerge with further discussion and must be included in this section. However, it does appear that, on balance, the potential benefits outweigh the risks. Indeed, some of the risks may be eliminated altogether through the application of the recently published Stage 1 competency standards, proper consultation and educational programs. Strategies must be developed to avoid the worst of potential pitfalls, especially as they relate to professional sensitivities and rivalries. The benefit to the engineering profession as a whole of the unified registration system must be strongly advocated. It is obviously to be preferred by the public to a plethora of fragmented registers with various professional and regional owners and vastly different standards.

8 ADVANCING THE PROPOSAL

- 8.1 There is some urgency in the needs identified in the building industry in Queensland, Victoria and NSW. An adequate registration system for persons providing fire safety certification and building compliance certification as a whole is needed, and Engineers Australia's involvement in this is widely supported.
- 8.2 The Stage 1 Competency Standards are deliberately generic in nature and are designed to provide both the benchmark for an accredited engineering educational program and the standard for a person entering the profession in the absence of such a qualification. Preparation of an individual's applications and its assessment is hindered by the need for the reader of the Stage 1 competency standards to be familiar with curriculum content of the corresponding educational program. A challenge faced by this proposal is to provide information on typical curriculum content.
- 8.3 Engineers Australia's Colleges, Technical Societies and the Articulation Committee will be invited progressively to provide advice on the comprehensive statements of competency and definition of fields of practice. In parallel key external organisations, like ACEA, AusIMM and APESMA, are being asked to provide their views and input to the proposal.

9 RECOMMENDATION

- 9.1 Members of the NERB Future Directions Working Party should consider the opportunities presented by this revised discussion paper and challenges presented by:
- Registering engineering technologists and ultimately engineering associates
 - Extending registration to cognate professions

- Developing a new blueprint for expanded guidelines on areas of practice incorporating all necessary Stage 1 and stage 2 competencies, including consideration of using examinations
 - Providing benchmark curriculum content to assist the use of Stage 1 competencies as an alternative route to registration.
- 9.2 Organisations and individuals receiving this discussion paper are invited to review the paper and to provide comments that will contribute to the development of the unified registration system for the purpose of:
- Better protecting the safety, health and welfare of the community;
 - More effectively overcoming the risks associated with information imbalance in the engineer client relationship;
 - Refining and improving the processes through which specific areas of practice come into being; and
 - Broadening the qualifications background of individuals registered to deliver engineering and engineering related services in the specific areas defined in the register.
- 9.3 The Board has endorsed the principles set out in the discussion of *towards a unified registration system* and has approved the revised discussion paper for publication.

Author:

Michael JM Bevan < mbevan@engineersaustralia.org.au >
Registrar, the National Engineering Registration Board

16 March 2007

Establishing new specific areas of practice

Defining Competency-Based Eligibility Criteria

- A1 The National Engineering Registration Board has developed a policy in relation to new areas of practice (see Attachment 1) that a proponent needs to satisfy before a competency panel is appointed.
- A2 The key to providing comprehensive definitions of eligibility criteria and meaningful descriptions of specific areas of practice has to be the composition of the Competency Panels appointed to establish them. The panels must include all legitimate stakeholders, such as the operators of amusement rides, who are represented in the panel for the specific area of practice for fairground and amusement equipment. Competency panels will also have to include persons who can decide the required minimum underpinning knowledge criteria in terms of mathematical techniques, modelling skills, control theory, mechanics, material science, fluid and thermodynamics and the ecology necessary to meet Stage 1 competency standards for the area.
- A3 The Competency Panel accepts responsibility for setting and maintaining the eligibility criteria for registration and the outline of the assessment methodology to be used. Specifically, the Competency Panel:
1. Establishes guidelines providing competency-based eligibility criteria, including Stage 1 competency knowledge criteria and the standard for registration in terms of competency at Stage 2
 2. Specifies nature of evidence to be provided by applicants
 3. Recommends suitable assessment procedures within the competency-based assessment framework
 4. Arranges for the independent assessment of the first members of an Assessment Panel
 5. Considers appeals against a refusal of registration, when consulted by the National Engineering Registration Board.
 6. Conducts compliance audits against registration requirements for practice currency and continuing professional development.
- A4 For each area of registration there also needs to be an Assessment Panel, comprising leading practitioners currently practising in the area of practice. Ideally, members of the Assessment Panel will also be experienced in reviewing statements of experience written against specified selection criteria. Panels will also need access to individuals with the academic experience necessary to assessing whether Stage 1 competencies expressed in terms of underpinning knowledge criteria. Members of the Assessment Panels can be appointed in all States and Territories, drawn from relevant colleges and societies and from all areas of the relevant industry (ies). The Assessment Panel can grow to meet demand, since further members can be invited to join it on the basis of their own applications and successful review.
- A5 The Assessment Panel accepts responsibility for reviewing applications and deciding the reasons for registering the applicants. Specifically, the Assessment Panel:
1. Reviews the applicant's CV, record of CPD and any other specified evidence of competency, including an engineering practice report or equivalent, if required
 2. Ensures Stage 1 competency knowledge criteria or qualifications requirements are satisfied
 3. Decides whether the evidence of competent practice (eg the engineering practice report) is convincing

4. Decides whether an interview is necessary to confirm claims of competency (at Stage 1 and Stage 2)
 5. Participates in the interview (if it is required) and confirms that the competencies claimed in the evidence provided meet the standard
 6. Confirms that the applicant possesses an understanding of an appropriate range of activities within the area of practice and satisfies the specified minimum Stage 1 knowledge criteria
 7. Decides whether further relevant qualifications, knowledge and/or experience are needed for registration
- A6 The Competency Panel and the Assessment Panel for an area of practice are formally established at arm's length from each other. Obviously there needs to be a dialogue that provides for feedback and improvement in documentation including appropriate modifications to the eligibility criteria, assessment procedures or the way those documents are drafted. Indeed it is often necessary for some key practitioners to have a seat on both panels. However, the separation of the competency setting body from the assessment body is considered to make the registration system more robust.
- A7 It is quite conceivable that an Assessment Panel could be faced with a candidate who appears to be practising competently in the field who has no qualification at all. In this case the panel will be required to make a careful assessment of whether the candidate meets the required Stage 1 competency knowledge criteria that are necessary to the specific area of practice. This may entail setting exams, designing projects or requiring the completion of technical assignments to provide the evidence necessary to complete the competency assessment.
- A8 It is important to note that the conceptual diagram (below) can not cover all possible interrelationships. More will become apparent as further real examples emerge. The purpose of the diagram is to show the flexibility of the unified registration system and to illustrate its potential operation.
- A9 It should also be noted that many areas of practice will be identified that cannot meet the Board's policy for incorporating them into the registration system. If there is no community protection issue or if there is no real risk associated with the information imbalance involved there will be no need to develop a specific area of practice unless there are other issues identified by community regulators that have led to a demand for regulation of practice in the area.

Conceptual diagram illustrating occupational groups qualifying for a specific area of practice

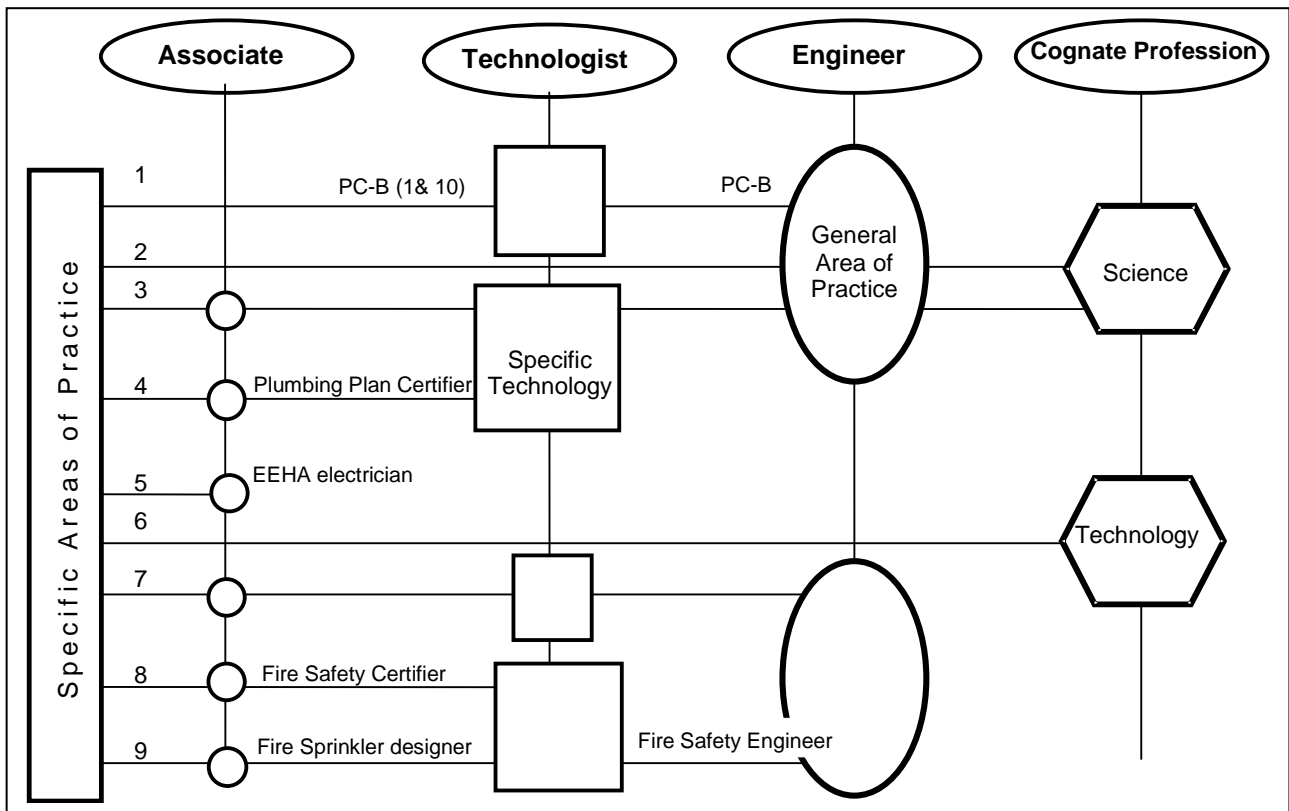

The conceptual diagram captures some possible interrelationships between the occupational groups within an industry where common practice may mean:

1. Engineering Technologists and Engineers practise – for example in the area building certification
2. Engineers work along side scientists – for example in Road Safety Auditing, environmental control
3. All occupational groups are fully involved – for example in Management
4. Associates and Technologists, who are familiar with water and waste-water codes and regulations in ACT, cover the practice with little or no input from Engineers
5. Only Associates need registration
6. Geologists or environmental scientists practise in this area (as certified by AusIMM)
7. Engineers, technologists and associates work competently in housing design
8. Associates or technologists working with the BCA as designers or certifiers
9. Associates work with standards specified by engineers or technologists on particular designs or installations

NATIONAL ENGINEERING REGISTRATION BOARD
POLICY FOR ESTABLISHING NEW AREAS OF PRACTICE

The following criteria, based on the Board's Terms of Reference, are intended to assist the Board in the consideration of the merits of proposals for new general and specific areas of practice.

1. DISTINCTIVENESS

How is the new area distinct from existing general and specific areas of practice?

Can the proposed area of practice be accommodated within one of the general areas of practice? (Advice should be obtained from relevant colleges on the proposal.) A very high threshold of distinctiveness must be shown to establish the need for a new general area of practice compared to a new specific area.

2. SUITABILITY OF REGISTRATION

Is the registration of practitioners the most appropriate form of regulation for the proposed area of practice?

How is this activity currently regulated? Have alternative means of safeguarding the community, eg certification, codes of practice, endorsed standards, been explored? Does any government list practitioners?

3. COMMUNITY NEED OR NEED FOR PROTECTION

Is there a demonstrable need of the community, government or industry for this area of practice or a risk to public health or safety if practitioners are not registered?

Do unregistered practitioners pose a significant risk to the community? What are the health and safety risks to the community if the proposed practice area is not registered? What information is currently available to consumers about the services offered? Does the imbalance of knowledge between the procurer and provider of engineering services provide a risk?

4. ENGINEERING INVOLVEMENT

Is there a sufficient level of engineering involvement in the field of activity?

Does the proposed area of practice involve only engineering professionals or is it multidisciplinary? Is the proposal compatible with a unified registration system, comprising professional engineers, engineering technologists and engineering associates? What is the role of engineers in the new field of activity? How many engineering practitioners currently practise in the new area? Is the proposed area well established within industry and recognised by members of the profession?

5. PRACTICE OUTLINE

What broad body of knowledge provides the foundation for the new general area of practice? Or, in the case of a new specific area of practice, what specific body of knowledge or skills defines the area? Does the ability to practice depend on further study or on-the-job training by an experienced specialist practitioner?

ESTABLISHING NEW AREAS OF PRACTICE FOR REGISTRATION

